

# Option

- **Extended hopper**

(MNS · MBS)

An extended hopper with an expanded capacity is available for compact feeders. The frequency of loading nuts and bolts to the hopper can be reduced.

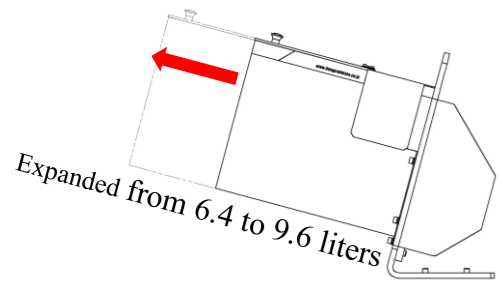

- **Nut orientation guide**

(MNS · VN)

It may be necessary to designate the welding direction of the nut. In such cases, nuts can be set in the specified orientation.

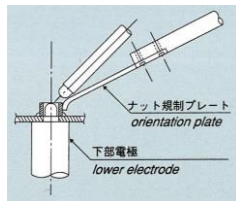

- **Double feed unit**

(VN · VB)

Nuts and bolts can be supplied from one main unit to two feed units.

- **Feeder interface**

(MNS · MBS · VN · VB)

Our feeders can be easily connected with our NDZ series spot welding machines using the HARTING connectors. Power to the feeder is supplied from NDZ, so there is no need to prepare a separate power supply.

(Though Nanaboshi Connectors are also available as option, power source for feeder must be prepared individually, separately from welder.)

- **300mm stroke**

(MNS · VN · MBS · VB)

Feed unit ideal for deep workpiece shapes. Ask us if 200mm stroke causes interference.

- **Compatible with robotic systems**

(MNS · VN · MBS · VB)

Status of the feed unit can be checked from the robot by installing a retracting end switch to the feed unit.

**MNS: Compact nut feeder**

**VN: Vibratory nut feeder**

**MBS: Compact bolt feeder**

**VB: Vibratory bolt feeder**

# AUTOMATIC FEEDER

Significant improvement in production efficiency and environment

- **Compact Feeder - Nut Feeder and Bolt Feeder**

1. **Quiet**

Quiet sorting sound

2. **Space saving**

Nut feeder: Less than A3 (11" x 17") paper floor space

Bolt feeder: Less than A2 (17" x 22") paper floor space

3. **Cassette type sorting unit**

Removable and easy to clean

Nut and bolt sizes can be changed by replacing the unit

4. **Low power consumption**

Only 40W power consumption

5. **Dust-proof hopper**

Cover prevents contamination from entering



- **Vibratory Feeder - Nut Feeder and Bolt Feeder**

1. **Wide range of variations**

Compatible with various nuts and bolts

2. **Wide range of options**

Flexible feeding patterns

3. **Stable quality**

Long and extensive sales history



Registered company: Dengsha Toa Co., Ltd.  
Scope of registration: Design, development, manufacturing, and related service for resistance welders and related equipment (product operation and maintenance training and service/spare parts supply)  
Related facilities: [Scope of activities: Same as above]  
Headquarters, Toyama plant, and Omi plant

**Branch**

DENGSHA AMERICA CORP.	U.S.A.	Tel +1(440)439-8081
DENGSHA MEXICO S.DE R.L.DE C.V.	Mexico	Tel +52(477)226-9327
DENGSHA EUROPE LTD.	U.K.	Tel +44(1543)481844
DENGSHA EUROPE GmbH	Germany	Tel +49(6432)80005-0
PT. DENGSHA INDONESIA	Indonesia	Tel +62(267)415-807
DENGSHA (THAILAND) CO., LTD.	Thailand	Tel +66(2)399-3201
DENGSHA INDIA PVT.LTD.	India	Tel +91(44)2233-1033

U.S.A./Mexico  
[dengsha.com](http://dengsha.com)

U.K.  
[dengsha.co.uk](http://dengsha.co.uk)

Germany  
[dengsha.de](http://dengsha.de)

# Nut Feeder Feed Unit

## Wide range of variations

### ● Magnet Type

Securely holds the nut with permanent magnetic force. Low magnetic force at the tip of fully extended spindle securely delivers the nut to the electrode.

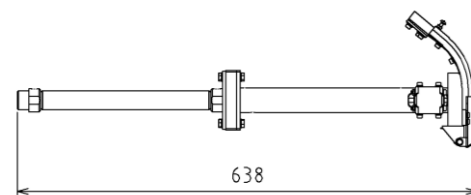

### ● Magnet-less Type

Cylinder holds nuts on elongated nose pin using inertia. Available for feeding non-magnetic nuts.

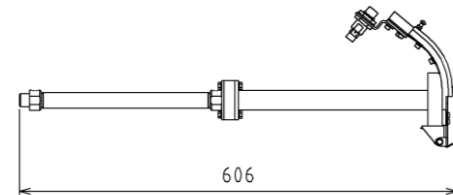

### ● Compact Type

Total length of the feed unit is significantly shorter and feasible for space saving. (M6/M8 square nuts)

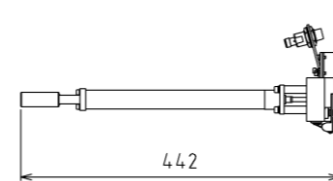

### ● Upper Electrode Supply Type

Patented linkage allows nuts to be fed to the upper electrode. Feasible to shorten the cycle time and supply nuts to deep drawn parts. Total length of the feed unit is significantly shorter and saves space. (M6 to M10 square nuts)

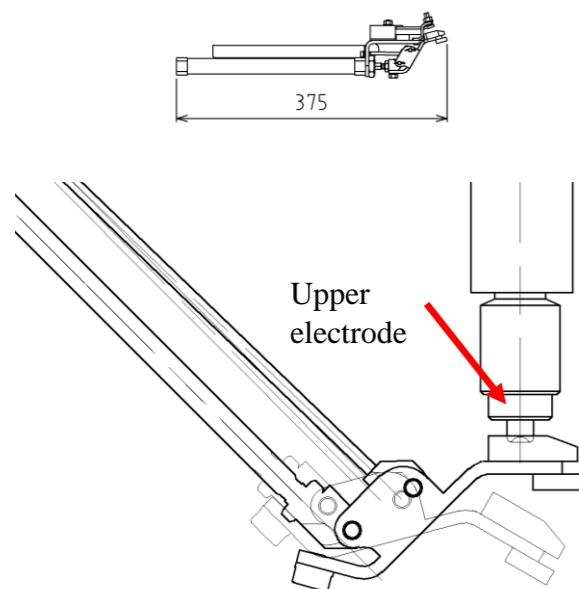

## Specification

### ● Compact Feeder

### ● Vibratory Feeder

Model	MNS-**-**-D*N-*	VN*-**-**-D*H-*
Power supply voltage	AC 100 - 230V 50/60Hz	AC 100 - 230V 50/60Hz
Air pressure	0.4 - 0.6MPa	0.4 - 0.6MPa
Applicable nut shape	Square nut, hexagon nut, hexagon nut with guide, round nut, round nut with guide, hexagon nut with round flange, round nut with round flange.	Square nut, hexagon nut, hexagon nut with guide, round nut, round nut with guide, hexagon nut with round flange, round nut with round flange, T-shaped nut, round nut with rhombic flange
Applicable nut size	M6 to M12 (O.D. Max. φ26)	M4 to M12
Sorting capacity	30 pcs/min	30 pcs/min
Hopper capacity	6.4 liters	7 liters (Bulk Hopper)
Control method	PLC-controlled (OMRON, Rockwell, Siemens)	PLC-controlled (KEYENCE, Rockwell, Siemens), PCB: printed circuit board
Feed unit	Single	Single, double
Weight	Approx. 40kg	Approx. 80kg

NOTE)

The above specification shows an example of a representative model. Please contact us for detailed specifications.

## EXTERNAL DIMENSIONS

### ● Compact Feeder

### ● Vibratory Feeder

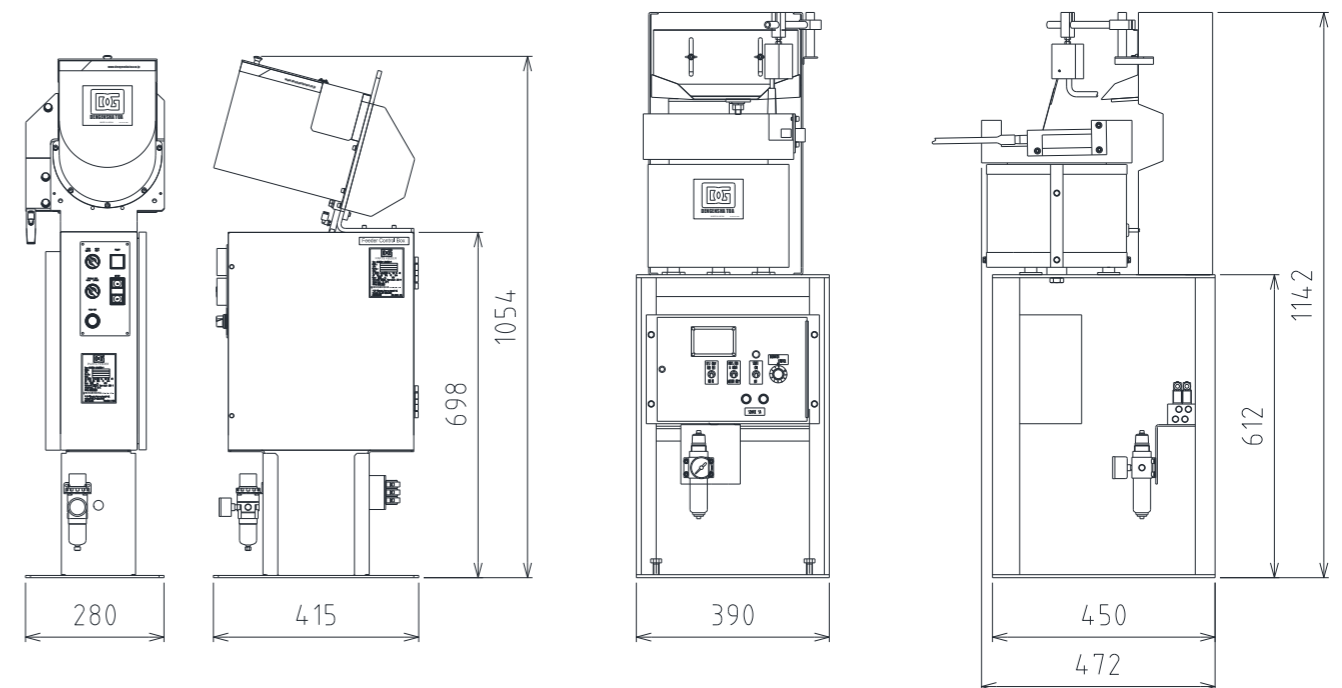

NOTE)

The above dimension shows an example of a representative model. Please inquire about the actual dimensions.



You can watch videos on YouTube.  
<https://www.youtube.com/watch?v=jrE1gk-CiZw>



# Bolt Feeder Feed Unit

Wide range of variations

## ● Chuck Type

When placing bolts into the panel, the bolt orientation must be kept vertical. Dengensha Toa's proprietary method – opening the chuck while pushing the bolt in - securely delivers bolts to the electrode.

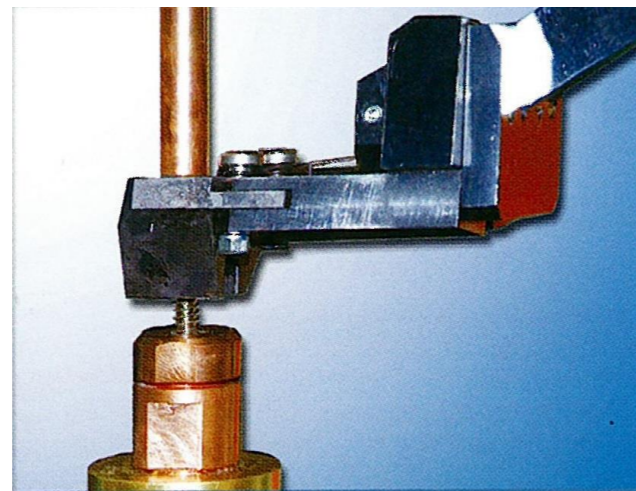
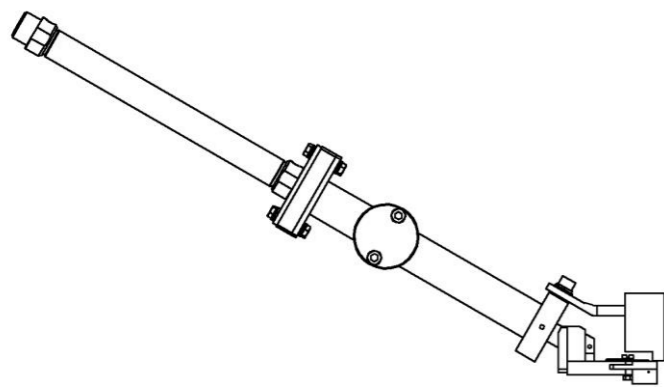

## ● Suction Type

The suction method is available for bolts with a short beneath length.

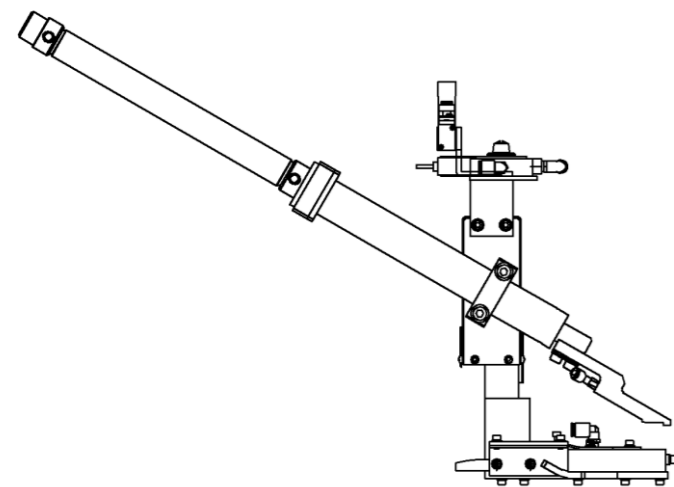

## Specification

### ● Compact Feeder

### ● Vibratory Feeder

Model	MBS-00-**-**/**-D*N-*	VB*-**-**/**-D*H-*
Power supply voltage	AC 100 - 230V 50/60Hz	AC 100 - 230V 50/60Hz
Air pressure	0.4 - 0.6MPa	0.4 - 0.6MPa
Applicable bolt shape	Welding bolt (3-point projection, 4-point projection, ring projection)	Welding bolt (3-point projection, 4-point projection, ring projection)
Applicable bolt size	M5-M10 Head beneath length: 30mm or less Head diameter: less than 23mm	M5-M12 Head beneath length: less than 33mm, Head diameter: less than 21mm
Sorting capacity	15 pcs/min	30 pcs/min
Hopper capacity	6.4 liters	7 liters (Bulk Hopper)
Control method	PLC-controlled (OMRON, Rockwell, Siemens)	PLC-controlled (KEYENCE, Rockwell, Siemens), PCB: printed circuit board
Feed unit	Single	Single, double
Weight	Approx. 50kg	Approx. 90kg

NOTE)  
The above specification shows an example of a representative model. Please contact us for detailed specifications.

## EXTERNAL DIMENSIONS

### ● Compact Feeder

### ● Vibratory Feeder

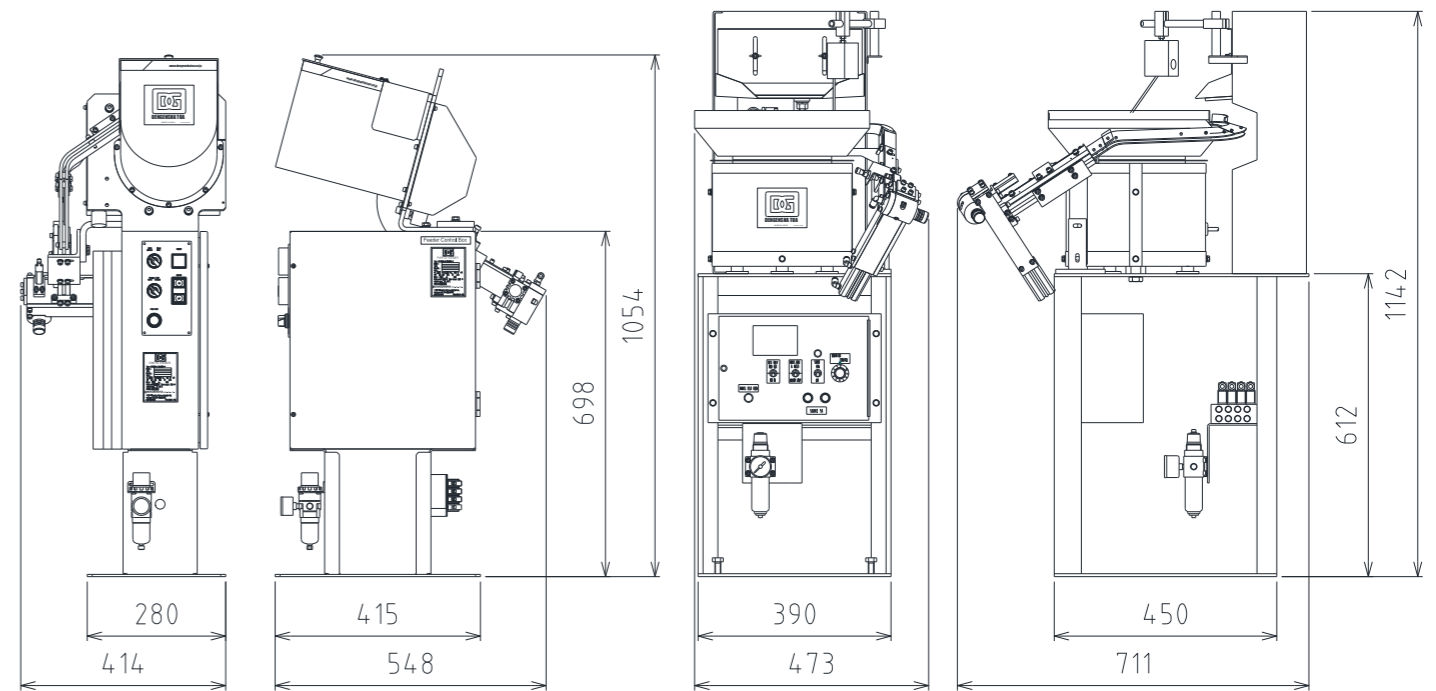

NOTE)  
The above dimension shows an example of a representative model. Please inquire about the actual dimensions.

# Model Indication

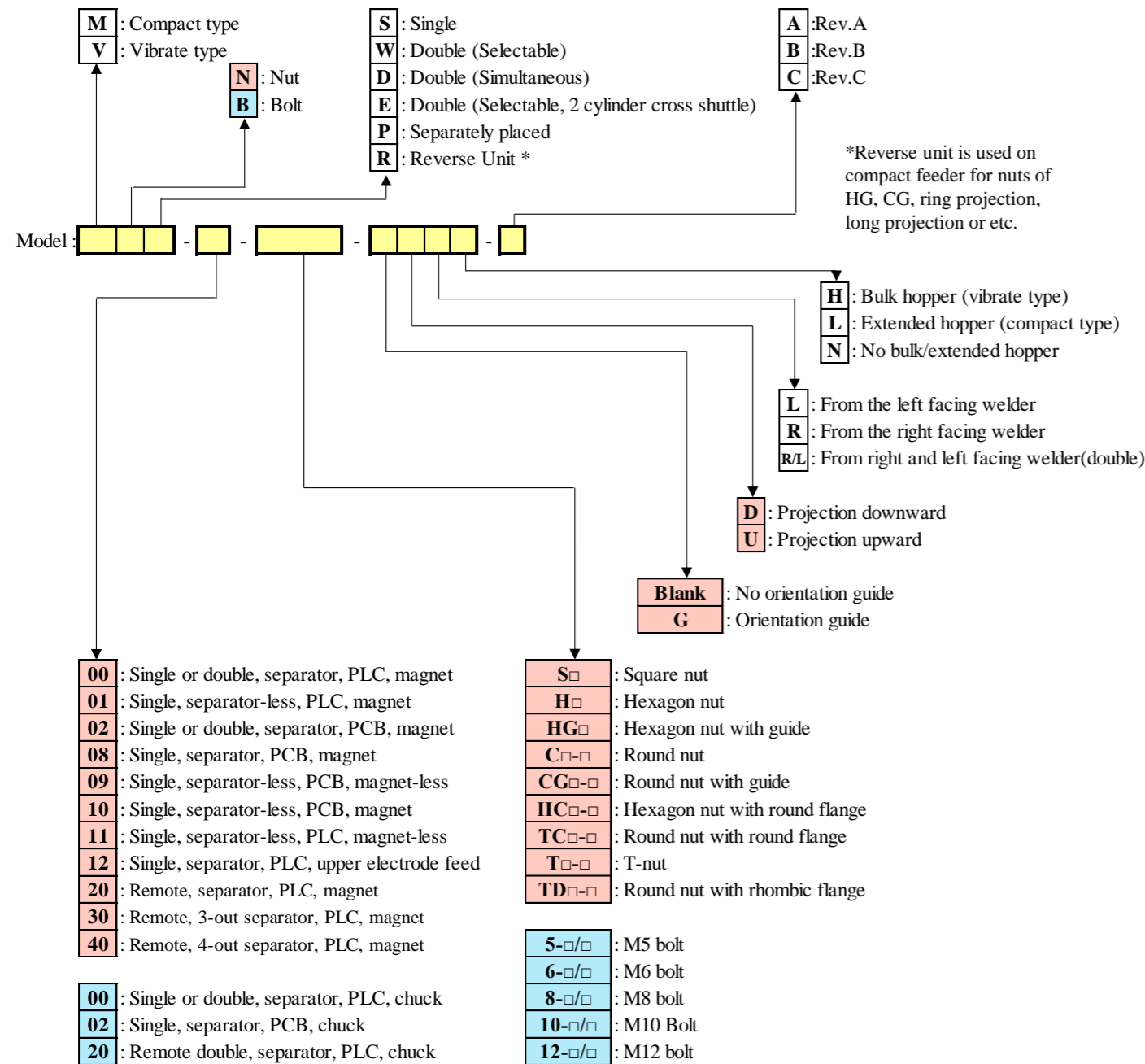

## MODEL EXAMPLE

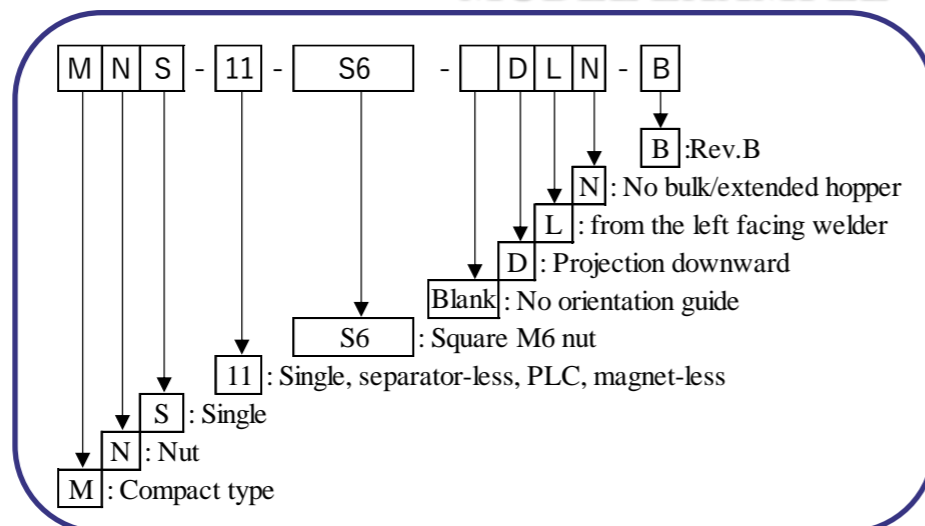

NOTES)  
 Depending on the type of feeder, compatible nuts and bolts as well as combinations for available options will vary. Please contact us for details.

# Q&A Frequently Asked Questions and Answers

## Q. What is a feeder?

A. This equipment supplies welding nuts and bolts to electrodes of resistance welding machines. A large number of feeders are used in the automotive body parts manufacturing process.

## Q. Why do you use the feeder?

A. Using a feeder prevents the risk of operator injuries on welders, which may occur with manual feeding. Since nuts and bolts can be supplied in a shorter time, work efficiency will also improve. Feeders are also used when panels are transferred by robots.

## Q. Why is the feeder of Dengensha chosen?

A1. When a resistance welder and a feeder are manufactured by different manufacturers, it takes time to connect or assemble them. As a welding machine manufacturer, Dengensha Toa can provide both feeders and welding machines together with easy connection. Pre-assembly of a feed unit to the welding machine is available as an option, so you can use it immediately after unpacking.

A2. Dengensha Toa has a long history of global presence. We provide feeders that match the standard of the destination. Our comprehensive local support is well received by many customers.

A3. In an unlikely event of a problem in use, if the welding machine and the feeder are of different manufacturers, it may be difficult to identify the problem. If both the welding machine and feeder are made by Dengensha Toa, there is no need to isolate the problem.

## Q. What types of feeders do you have?

A. Compact-type feeders and vibratory-type feeders are available at Dengensha Toa.

Compact feeders offer reducing an installation area and superior quiet operation compared to vibratory feeders. (Non-magnetic nuts and bolts, such as SUS304, are not applicable to this type of feeders due to its magnetic structure.)

Vibratory feeders are extensively applicable to a wide range of nuts and bolts, and many options are available.

Please select according to your application environment.

## Q. What types of feed units do you have?

A. Magnetic feed units are commonly used, but shorter and simpler compact feed units are recommended for M6 and M8 square nuts. Magnetless feed units are also available for non-magnetic nuts, such as SUS304.

If you want to shorten the cycle time as much as possible, or if you are unable to feed nuts with a regular feed unit for a deep drawn part, our upper electrode feed unit (for square nuts) is available.

In addition, pick-and-place type feed units and suction-type feed units are also available. Please contact Dengensha Toa for more information.